

## Applications

- Deep bed vertical epoxy coated carbon steel tanks for use in industrial water treatment applications where longer contact time is required.
- For use in irrigation systems where greater depth of media may be needed.

## Features

- Suitable for use with sand, gravel or a combination of both media.
- Maximum pressure : 800 kPa
- Tanks available in 300, 400, 500, 635, 760, 900, 1220 and 1500mm diameter.
- Tanks sold separately, not as part of array

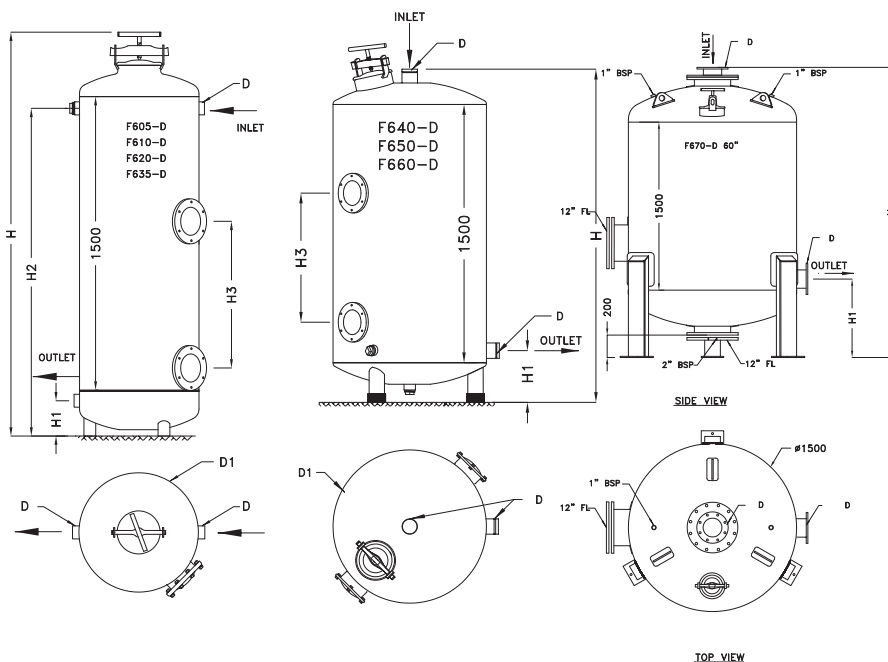

PVT600-D Epoxy Coated Vertical Deep Bed Media Tanks Dimensional Drawings

### Technical Data

Code	Diam. D1 mm	D mm	H mm	H1 mm	H2 mm	H3 mm	Filtration Area (m <sup>2</sup> )	No. of 25kg bags*	Weight of tank only (kg)
F605-D	300	25 FBSP	2000	150	1615	750	0.073	5	66
F610-D	400	40 FBSP	2055	150	1750	750	0.126	8	70
F620-D	500	50 FBSP	2065	180	1675	750	0.195	12	95
F635-D	635	50 FBSP	2065	180	1675	750	0.317	20	143
F640-D	762	80 Vic	1960	300	N/A	750	0.456	26-28	214
F650-D	915	80 Vic	1935	300	N/A	750	0.657	38-40	250
F660-D	1200	100 Vic	2155	420	N/A	750	1.168	42-44	380
F670-D	1500	150 Fl (D)	2590	700	N/A	750	1.767	102-104	1000

\*Recommended media depth 1000mm.