

633 | ACCU-PRO AC/SC SPIN /RELIEF REEL GRINDER

FOLEY COMPANY



FEATURES

SPIN GRIND CAPABLE	✓
AUTO INDEXING HANDS FREE RELIEF GRINDING	✓
- ELECTRONICALLY CONTROL TORQUE FOR RELIEF	✓
QUICK REEL PLACEMENT - ACCU-REEL SELECTOR	✓
CONE/TAPER REMOVAL - EASY ALIGNMENT OF REEL TO GRINDER	LED- FEEDBACK (MANUAL) SCREEN FEEDBACK (OPTIONAL AT3 PACKAGE)
VARIABLE SPEED SPIN DRIVE MOTOR	ARTICULATING COUNTER BALANCED
VARIABLE SPEED BELT DRIVE TRAVERSE SYSTEM	✓
3 PACK OF DRIVE ADAPTERS (MALE - 8, 9 AND 11 TOOTH SPLINE)	✓
REAR DOOR WITH SAFETY INTERLOCK	✓
FRONT SAFETY DOOR WITH SAFETY INTERLOCK	✓
QUICK CHANGE GRINDING WHEEL	✓

OTHER:

ACCU-TOUCH 3 (AT3) WITH STANDARD AND CUSTOM PROGRAMS - WITH END OF CYCLE INDICATOR LIGHT.	OPTIONAL
NOISE AND DUST ABATEMENT	X
DUST COLLECTION - VACUUM SYSTEM	OPTIONAL
SLOTTED TOP CANOPY (653 ONLY) FOR SHOP OVERHEAD CRANE	X
ATTACHED REAR LIFT TABLE	OPTIONAL
PORTABLE WORKSTATION COMPATIBLE	✓
OVERHEAD BOOM	OPTIONAL ELECTRIC WITH TOLLEY

▶ DIMENSIONS:

TOP VIEW

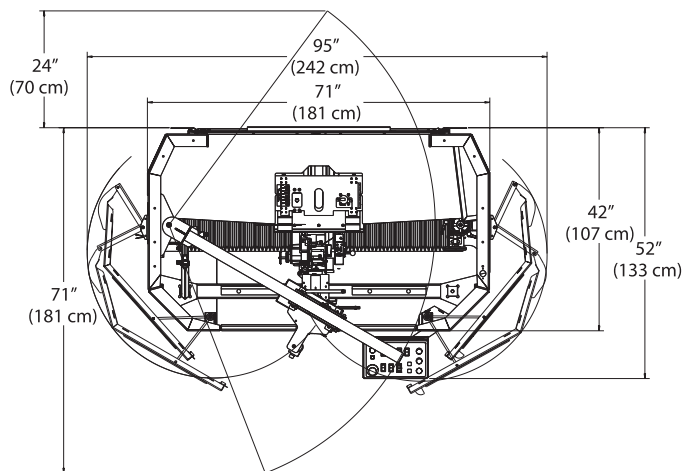

SIDE VIEW

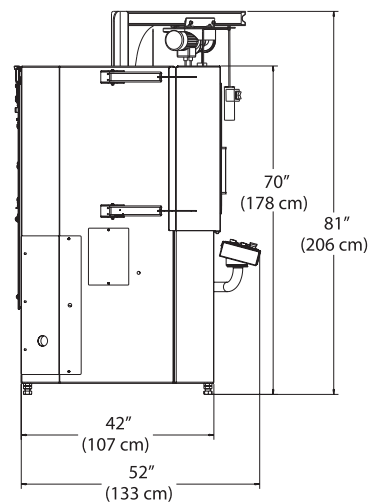

MADE IN THE USA

©2019 FOLEY COMPANY. ALL RIGHTS RESERVED. PNG3730169 - LU10072019

FOLEYCO.COM | 800.225.9810

PRECISION AT PLAY

633 | ACCU-PRO AC/SC SPIN /RELIEF REEL GRINDER

FOLEY
COMPANY

SC/AC CONTROLLER



ACCU-REEL SELECTOR



ELECTRONIC POSITIONING DISPLAY



FRONT ROLLER CLAMP



COUNTER-BALANCED SPIN DRIVE



ACCU-POSITIONING GAUGE



PATENTED GRINDING HEAD & RELIEF ASSEMBLY

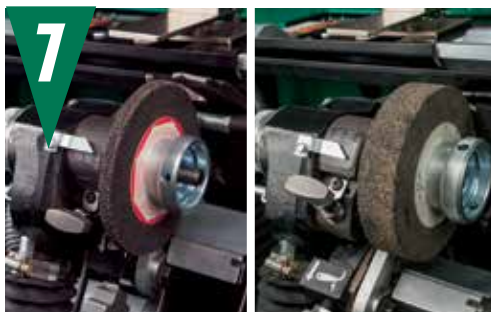

OPTIONAL ELECTRIC HOIST



SIMPLICITY + QUALITY AT ITS BEST



OPTIONAL EQUIPMENT
REAR LIFT TABLE

AUTOMATED INFEED GRIND CYCLES

FOR BOTH THE SPIN AND RELIEF GRIND PROCESS. (633AC)

SPIN GRIND IN MINUTES

LET THE ACCU-TOUCH 3 DO THE WORK WHILE YOU DO SOMETHING ELSE. (633AC)

AUTO INDEX RELIEF

AUTOMATION OF INFEEDS AND THE PATENTED AUTO-INDEX PROVIDES PRODUCTIVITY AND CHOICE.

EASY REEL PLACEMENT

TO AUTOMATICALLY LOCATE THE REEL FOR A FAST AND EASY SPIN OR SPIN + RELIEF GRIND.

EASY TO USE CONTROLS

THE 633 SC USES A PRECISION PUSH-BUTTON TO INFEED THE GRINDING HEAD WHILE IT AUTOMATICALLY TRAVERSES. THE 633 AC AUTOMATES THE PROCESS TO AUTOMATICALLY IN-FEED THE GRINDING HEAD AND STOP THE GRINDING PROCESS WHEN COMPLETED.