

672/673 SEMI-AUTOMATIC & AUTOMATIC BEDKNIFE GRINDERS

STANDARD FEATURES:

- “AUTOMATIC ANGLE” POSITIONING
- “AUTOMATIC ALIGNMENT” POSITIONING
- ELECTROMAGNETIC BEDKNIFE MOUNTING SYSTEM
- BUILT-IN DIAMOND DRESSER
- INTEGRATED FLOOD COOLANT SYSTEM
- SUPPLEMENTAL BACK-UP POWER SUPPLY
- GRINDING MOTOR HEIGHT ADJUSTER
- AUTOMATED INFEEED/TRVERSE PROGRAMS (MODEL 673)

OPTIONAL EQUIPMENT ::

- BELLOWS KIT FOR COMPONENT PROTECTION
- BORAZON GRINDING WHEEL FOR HARDENED BEDKNIVES PART #3700696
- REPLACEMENT FLOOD COOLANT ADDITIVE

BECAUSE FOLEY IS CONTINUALLY IMPROVING ITS PRODUCTS, SPECIFICATIONS ARE SUBJECT TO CHANGE WITHOUT NOTICE.

FOLEY
COMPANY

PRECISION AT PLAY

P: 1.715.426.5151
TOLL FREE: 1.800.225.9810
FOLEYCO.COM

WEIGHT :: 20 LBS (372 KG)

DIMENSIONS ::

TOP VIEW

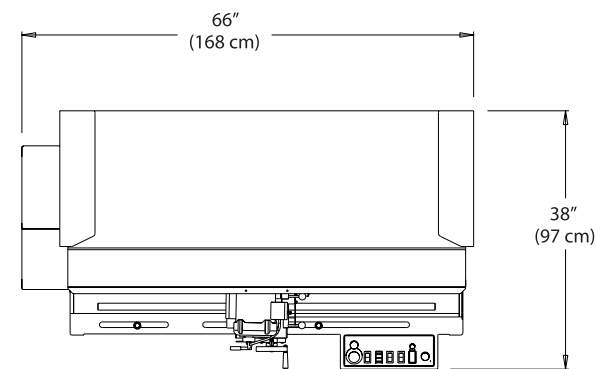

SIDE VIEW

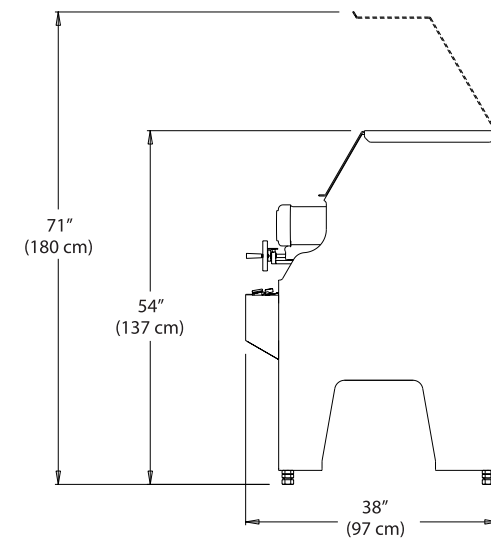

DISTRIBUTED BY:

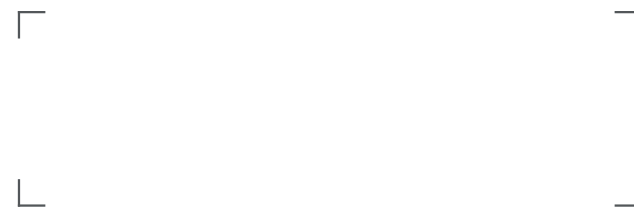

MADE IN THE USA

©2019 FOLEY COMPANY. LIT-2019-10005

FOLEY
COMPANY

672/673 SEMI-AUTOMATIC + AUTOMATIC BEDKNIFE GRINDERS



THE HIGHEST QUALITY GRIND IN THE WORLD JUST GOT EASIER

672/673 SEMI-AUTOMATIC & AUTOMATIC BEDKNIFE GRINDERS



1 ANGLE SET-UP



2 INTEGRATED FLOOD COOLANT



3 BUILT IN DIAMOND WHEEL DRESSER

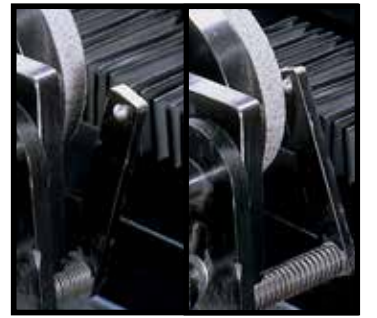

4 672 MANUAL IN-FEED CONTROL
673 AUTO IN-FEED CONTROL



5 SUPPLEMENTAL POWER SUPPLY



6 BELT DRIVE TRAVERSE SYSTEM



7 POWERED ANGLE ADJUSTMENT



8 ELECTROMAGNETIC MOUNTING SYSTEM

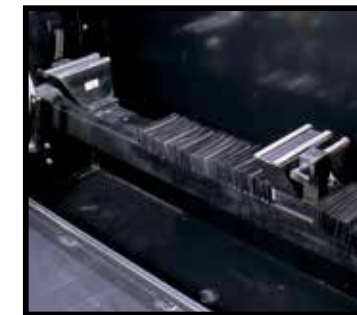

9 ALIGNMENT GAUGE



FASTEST + EASIEST
TO USE BEDKNIFE GRINDERS IN THE WORLD

LEARN MORE: FOLEYCO.COM

▶ 672/673 GRINDERS BOTH OFFER ::

AN INNOVATIVE BEDKNIFE MOUNTING SYSTEM
THAT USES POWERFUL ELECTROMAGNETS TO HOLD THE BED BAR IN PLACE MAKING SET-UP SIMPLE AND FAST. YOU CAN GRIND ANY BED BAR ARRANGEMENT WITHOUT ADDITIONAL TOOLING.

FAST ANGLE SET-UP
THAT PROVIDES REPEATABILITY WITHOUT RECALIBRATION. CHANGING FROM GRINDING THE FRONT FACE TO THE TOP FACE IS AS SIMPLE AS PUSHING A BUTTON AND WATCHING AS THE POWERED TOOL BAR ROTATES INTO POSITION

OPERATOR PROTECTION
PROVIDED BY A STURDY METAL HOOD WITH A CLEAR POLYCARBONATE WINDOW THAT RETAINS THE COOLANT MIST AND SHIELDS THE OPERATOR. THE INTERLOCKING SWITCH PREVENTS OPERATION WITHOUT THE HOOD BEING TOTALLY CLOSED. THE SUPPLEMENTAL POWER SUPPLY PROTECTS THE OPERATOR IN THE EVENT OF A POWER OUTAGE, MAINTAINING POWER TO THE ELECTROMAGNETS AND HOLDING THE BED BAR FIRMLY IN PLACE.

EASY-TO-USE CONTROLS
THE 672 USES A PRECISION HAND WHEEL TO IN-FEED THE GRINDING HEAD WHILE IT AUTOMATICALLY TRAVERSES. THE 673 AUTOMATES THE PROCESS BY USING ONE OF THE PRE-SET PROGRAMS TO AUTOMATICALLY IN-FEED THE GRINDING HEAD, AND STOP THE GRINDING PROCESS WHEN COMPLETED.