

Maintenance and Operating Instructions

Large area sprinkler

Type: P2S

PERROT



Contents

- 1. General**
- 2. Safety**
- 3. Description**
- 4. Assembly**
- 5. Commissioning**
- 6. Maintenance**
- 7. Malfunction and trouble-shooting**

1. General

We presume, that you are experienced in the field of irrigation. Therefore we have kept this instruction as briefly as possible, and have included such information only, which you must have for the use of this product.

A guarantee can be accepted only, if the sprinkler has been operated in accordance with these instructions, and if the defect occurs within the guarantee period.

1.1. Application

The sprinkler is used for the uniform distribution of the water. The water should be pre-cleaned, and free of coarse and fibrous impurities.

Max. water temperature will be 50 degree C.

Max. ambient temperature will be 75 degree C.

2. Safety

These operation and safety instructions include basic remarks and hints for the assembly, installation, operation, maintenance, inspection and repair. For this reason these instructions must be read by the fitter, as well as by the customers authorised staff, prior to the installation and commissioning.

Apart from the general safety instructions of this paragraph the special safety instructions include in other paragraphs of these operating instructions have to be observed also.

2.1. Symbols of hints given in these operating instructions

The non-observance of the safety instructions mentioned in these operating instructions can endanger persons, are

marked with the general danger symbol



especially.

Safety instructions which can endanger the sprinkler and it's function, if not observed, are specially marked and the word

WARNING

has been inserted.

2.2. Dangers if the safety instructions are not observed

Non-observance of the safety instructions can endanger persons as well as the environment and the sprinkler. Non-observance of the safety instructions can result in a loss of all claims for indemnity.

2.3



Operator / Owner has to guarantee that there are no persons in the operation area during running of the system.



Build in or erection of large area sprinkler over height of head. If not possible the use of other safety measures has to be taken.

3. Description

Recommended operating pressure 5 to 7 bar
Permissible operating pressure 4 to 10 bar

WARNING The pressure at the sprinkler must not exceed 10 bar.

For further data please refer to the separate data leaflet.

4. Assembly

- ☆ Threaded connection on the sprinkler is 2½" female thread.
- ☆ For sealing the thread, hemp and a jointing compound has to be used e.g. Fermit special
- ☆ To screw on the sprinkler, always use a pipe wrench size 3".
Tighten the sprinkler with around 30Nm.

WARNING Do not turn the sprinkler by using the jet pipe.



Sprinklers should be installed above head-height, respectively adopt any alternative safety measures.

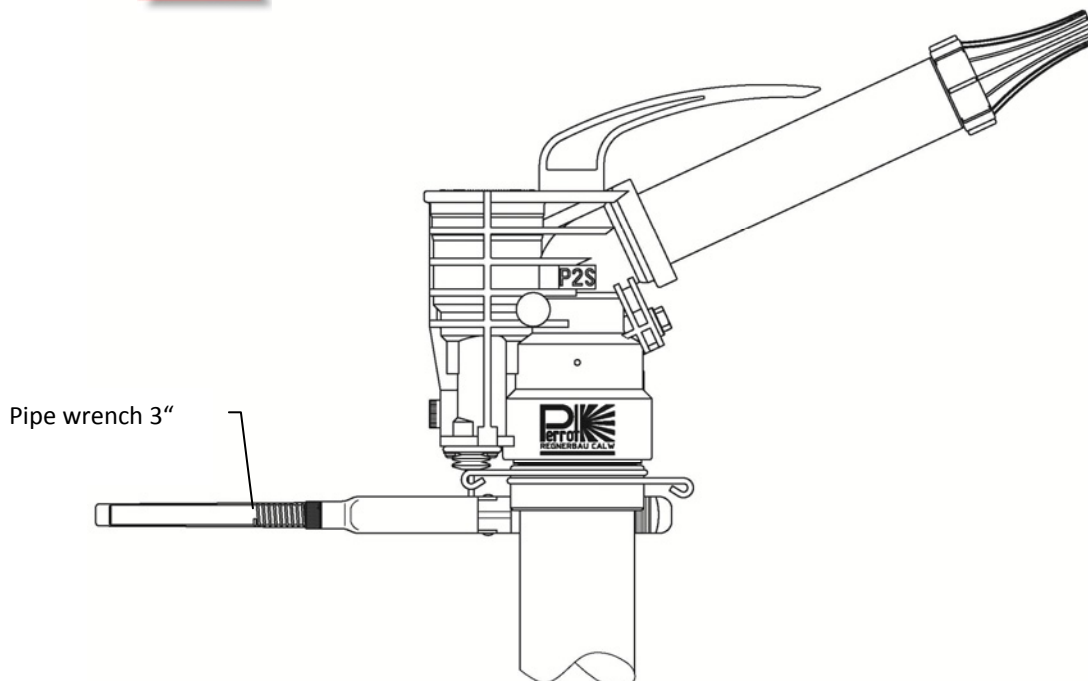

picture1

Screw on the connection socket up to the detent, so that the sprinkler cannot unscrew itself during operation.

5. Commissioning

There aren't any special measures necessary for commissioning.
Only the rotating speed of the sprinkler has to be adjusted as well as the part circle operation for the sector, which has to be irrigated.

5.1 Adjustment of Rotation Speed (for agricultural applications)

Turning the regulation screw to the right will lower the rotation speed



Option:

If a "K" is stamped in the speed regulation screw, the sprinkler can be stopped completely by turning the speed regulation screw to the right (from year of manufacture 2013).

By turning the regulation screw to the left the rotation speed is increased.

WARNING

***For minimal speed, the use of clear water is required.
In case dirty water is used, the regulation screw has to be opened completely; otherwise the sprinkler can stop its operation.***

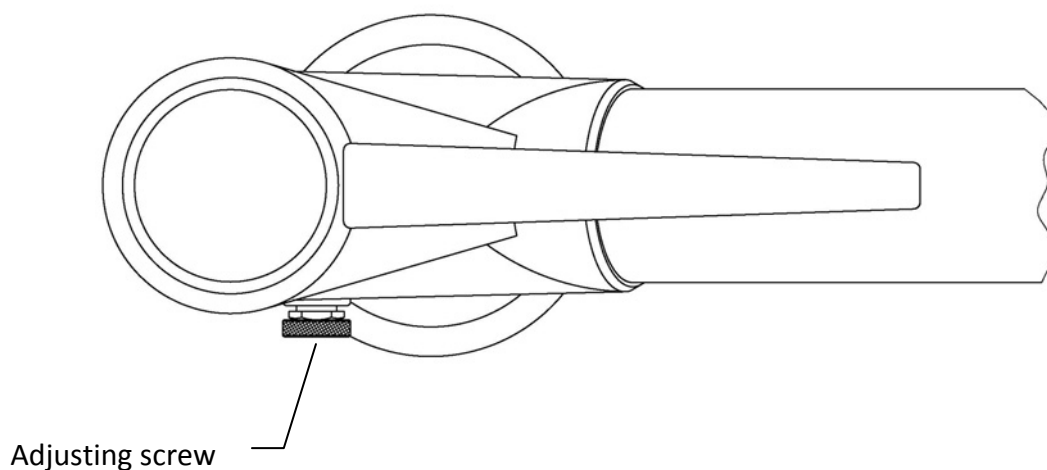

picture 2

5.2 Setting the part circle angle

Infinitely variable by pulling (not pressing) the relevant end of the upper or lower spring stop. The irrigated part circle has to be adjusted by the spring stops (see sketch).

Setting part circle angle

WARNING

Infinitely variable by pulling (not pressing) the relevant end of the upper or lower spring stop.

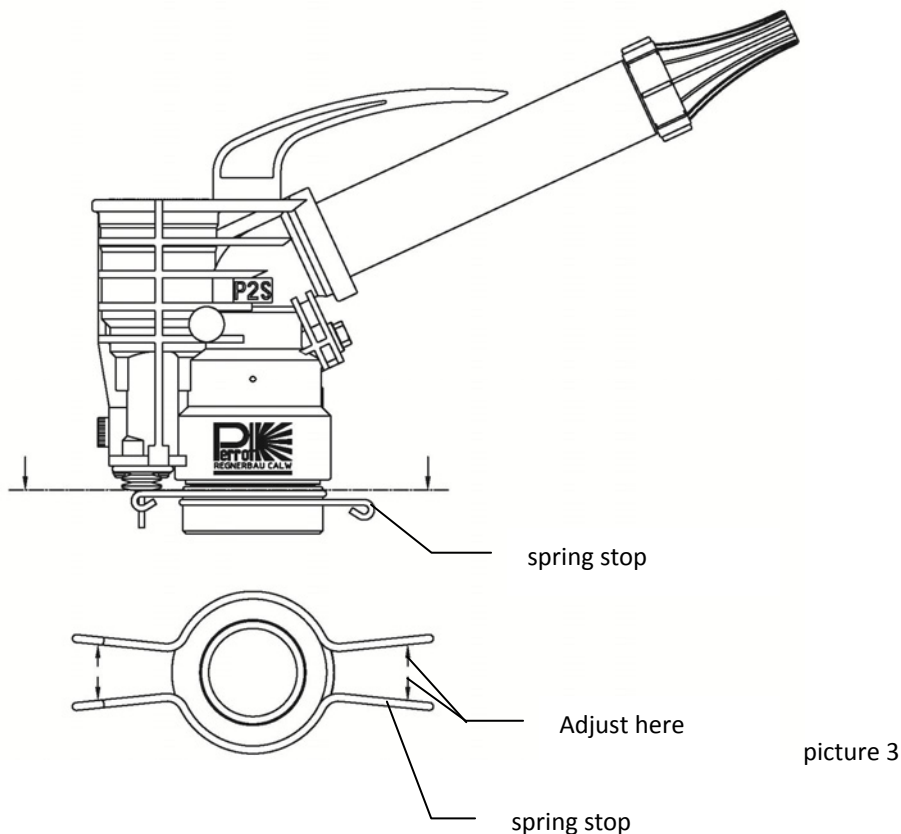

5.3 Full circle irrigation

For full circle irrigation the spring stops have to be removed.

WARNING

Only pull spring stops so far that you can slip them easily. In case of overstretching them, they can't be used again for part circle operation.

5.4 Winter proof

During the frost period please take care, that there is no water standing in the sprinkler. Remaining water in the piston drive does not cause frost damages. Is the sprinkler put again into operation, although in the piston area is still ice, it will take about 15 minutes to defrost the drive, when the ice temperature is approx. -20°C .

5.5 Putting into service in spring

The sprinkling head of the piston drive sprinkler is, due to the load alterations and the different installation conditions (humid, dry), exposed to extreme tensions. Under these conditions the piston can get axial play. In order to avoid interruptions of service, the piston cover should be tightened up at the putting into service in spring during its first and second year of operation as described below.



The cover has to be tightened up with the face spanner ZB98236 and an effort of approx. 10Nm. This means at a lever length of 10cm you have to mobilize a strength of 100N on the spanner.



Note:

After the 3rd and 4th winter there shouldn't be any more expansions.

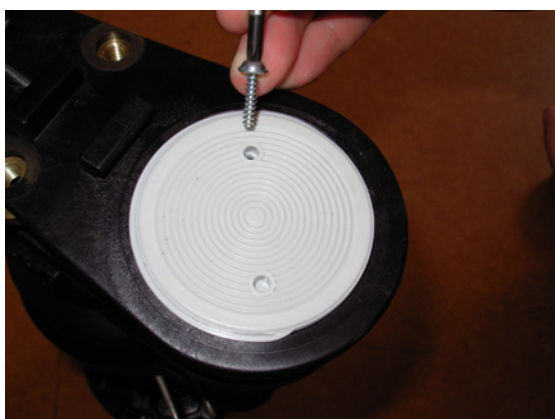

Option:

Before tightening up the grey cover, the safety screw has to be removed. After the adjusting of the grey cover, the safety screw has to be screwed in again.



The safety screw prevents an independent loosening of the grey cover.

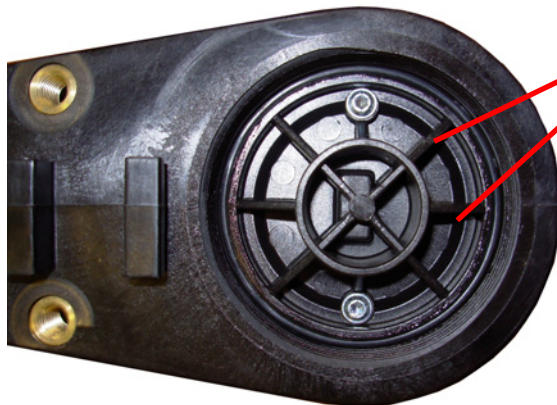

Stiffening ribs



Attention:

If the safety screw can't be tightened up, it hits a stiffening rib of the piston drive! In this case, the grey cover has to be pulled tighter, so that the safety screw passes the stiffening rib.

6. Maintenance

6.1 Lubricate the thread on the steel pipe

When changing the main nozzle, the thread on the steel pipe and on the O-ring seat should be cleaned and lubricated.

Therefore the nozzle can be removed easily by hand and also pulled again.

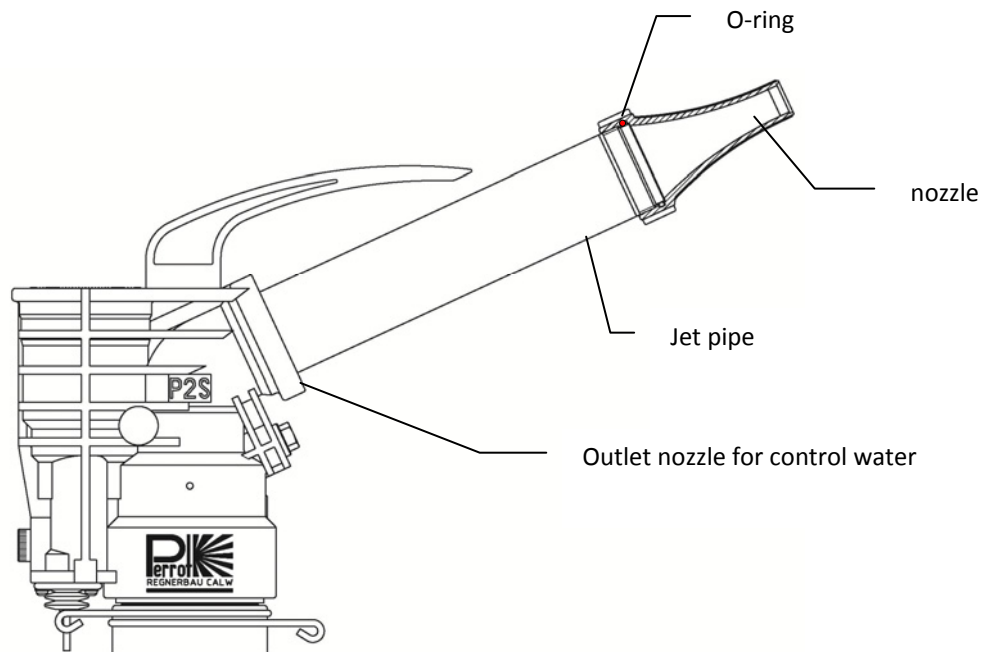

picture 4

6.2 Clean filter for control water

The drive of the sprinkler takes place with help of a cylinder. The control water is pre-cleaned by means of the filter. The cleaning interval has to be fixed in dependence of the level of the pollution and operating time.

Please use brush and high pressure cleaner for cleaning the filter.

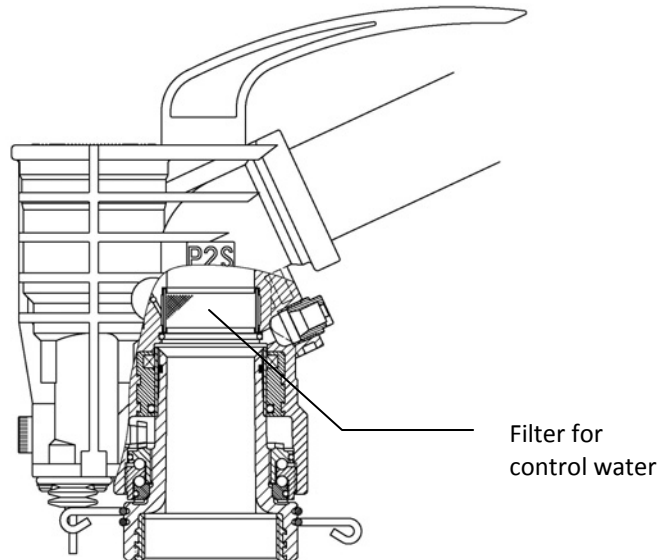

6.3 Clean piston drive and piston drive area

In case that the drive doesn't function because of much dirt, the piston drive has to be removed and cleaned.

6.3.1 Remove piston drive: (see TDP055e-rep)

7. Malfunction and trouble-shooting

Defects	Reasons	Elimination
Sprinkler doesn't rotate around or rotates only very slow. Sprinkler doesn't rotate at all.	The water is dirty. Speed regulation is adjusted at min. Filter is blocked.	Open regulation screw, dirt is flushed out. Clean filter, as mentioned in point 6.2 and 6.3
Sprinkler with bad water jet.	Nozzle or jet straightener never is contaminated.	Remove nozzle. Clean jet straightener. Take care of the right position of the draining and run in pipes when installing the nozzle, lubricate steel pipe thread.
Sector angle gets bigger during operation	Spring stop is loose. Spring strength is lamed. Spring stop is overturned.	Mount new spring stop.
Bearing of sprinkler is leaking.	Groove ring is worn out	Repair only possible by the manufacturer

Subject to change without prior notice.



CE-declaration of conformity

According to machinery directive (98/37/EG), appendix II A
According to low voltage directive (73/23/EWG)
According to electromagnetic compatibility directive (89/336/EWG)

Manufacturer : Regnerbau Calw GmbH
Industriestrasse 19-29
75382 Althengstett – Germany
Tel. +49-(0)7051-162-0

Explains hereby that the following product:

Product description: Large area sprinkler P2S
Year of manufacture: from 2009

Corresponds to the regulations of the guidelines designated above.

Following harmonizing standards were used:

DIN EN 292-1 EN 12100	Security of machines; fundamental terms, common guidelines; part 1: basic guidelines and specifications
DIN EN 1050	Security of machines; guidelines for assessments of risk
DIN EN 60204-1	Security of machines; Electrical equipment of machines; part 1: generals' requirements (IEC 204-1:1992, modified)

The manual belonging to the machine as well as the technical documentation is present in original version.

This declaration of conformity loses its validity, if changes are made at the machine, which were not coordinated with us before and approved in writing by us.

Althengstett,

28.09.2009

Date

Leiter tech. Büro, Günther Flük

Signatory and data to the signatory

Signature